

# Dual Comparator Thermally Protects Li+ Battery

*A dual comparator and thermistor set safe temperature limits for a lithium-ion battery charging circuit. The single-cell lithium-ion (Li+) battery charger can be powered from a USB port or external supply.*

Most manufacturers recommend that Li+ (lithium-ion) batteries not be charged below 0° C or above +50° C. You can monitor both of these limits by adding a thermistor and dual (window) comparator to a Li+ battery charger (Figure 1).

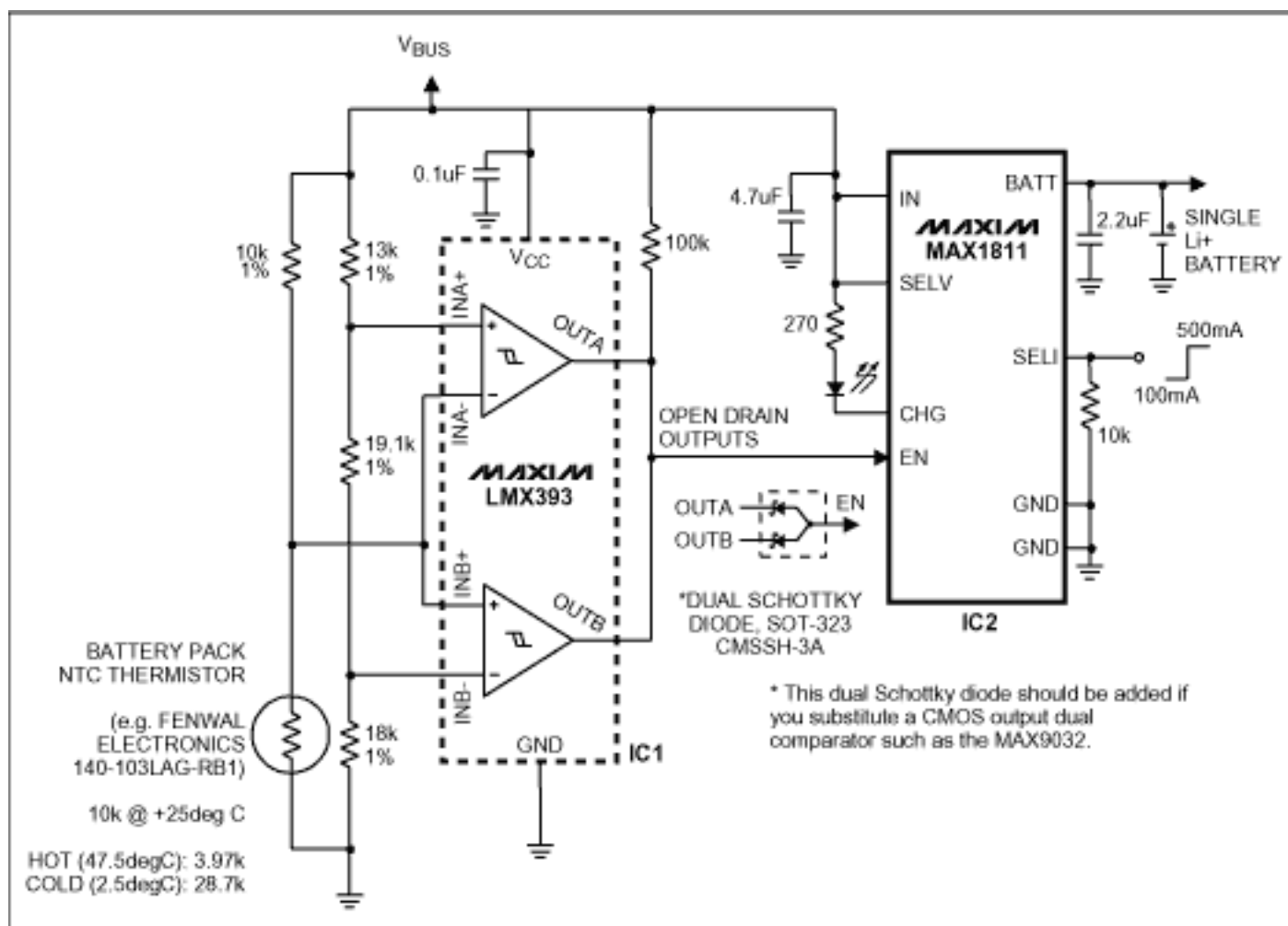

Figure 1. This lithium battery charger derives its power from a USB port and provides thermal protection for the battery.

The circuit has a low-temperature trip point of +2.5° C and a high-temperature trip point of +47.5° C. A precision voltage reference is not necessary. Because the comparator resistor

network is ratiometric, variations in the supply voltage ( $V_{BUS}$ ) do not affect the trip thresholds.

By driving the charger's enable input (EN), the comparators' open-drain outputs inhibits charging when the battery temperature is out of range. As an alternative, you can substitute a dual comparator with push-pull CMOS outputs (such as the MAX9032) if you also add a tiny, SOT-323 dual diode, as shown in dashed lines.

The dual comparator shown and the MAX9032 are available in tiny SOT23 packages, and both offer a built-in hysteresis of 2mV or 4mV respectively.

IC2 is a single-cell lithium-ion (Li+) battery charger that can be powered directly from a USB port or from an external supply up to 6.5V. The accuracy of its battery-regulation voltage (0.5%) allows maximum utilization of the battery capacity.

The charger's internal FET delivers up to 500mA of charging current, and its SELV input can be configured for charging a 4.1V or 4.2V battery. The SELI input sets the charge current to either 100mA or 500mA, and an open-drain output (CHG) indicates the charge status. For near-dead batteries, a preconditioning capability soft-starts the cell before charging. Other safety features include continuous monitoring of voltage and current, and initial checking for fault conditions before charging.

### More Information

LMX393: [QuickView](#) -- [Full \(PDF\) Data Sheet](#) -- [Free Samples](#)

MAX1811: [QuickView](#) -- [Full \(PDF\) Data Sheet](#) -- [Free Samples](#)

MAX9032: [QuickView](#) -- [Full \(PDF\) Data Sheet](#) -- [Free Samples](#)